

FREEWAY BUSINESS PARK
1950 COMPTON AVENUE, CORONA, CA 92881
INDUSTRIAL / OFFICE UNITS FROM ± 2,304 - 15,000 SF

1950 COMPTON AVE
UNITS 101 -116



BUILDING FEATURES

INDUSTRIAL / OFFICE UNITS APPROXIMATELY 2,304 -15,000 SF
EXCELLENT 15 FREEWAY VISIBILITY / NEAR ON & OFF RAMPS
LARGE YARDS
12' X 14' GROUND LEVEL DOORS
APPROXIMATELY 19' CLEARANCE / CLEAR SPAN
GREAT CORPORATE NEIGHBORS / RETAIL SUPPORT
NEAR HOME DEPOT SAM'S CLUB CENTER
EASY ACCESS TO THE 91 & 15 FREEWAY
FOIL CEILINGS / SKYLIGHTS
SPRINKLERED / M4 ZONING
HIGH QUALITY CONSTRUCTION
GREAT TRUCKING

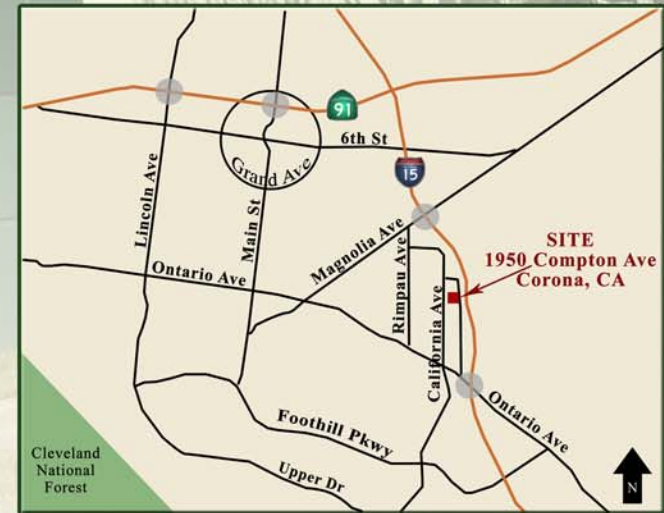

DOUG C. EARNHART, SIOR
LICENSE #00884396
DEARNHART@LEE-ASSOC.COM

PAUL R. EARNHART, SIOR
LICENSE #00822072
PEARNHART@LEE-ASSOC.COM



3535 INLAND EMPIRE BLVD ONTARIO, CA 91764 P.909.989.7771 F.909.373.2968

NO WARRANTY OR REPRESENTATION IS MADE TO THE ACCURACY OF THE FOREGOING INFORMATION. TERMS OF SALE OR LEASE AND AVAILABILITY ARE SUBJECT TO CHANGE OR WITHDRAWAL WITHOUT NOTICE.

FREEWAY BUSINESS PARK

1950 COMPTON AVENUE, CORONA, CA 92881

INDUSTRIAL / OFFICE UNITS FROM ± 2,304 - 15,000 SF

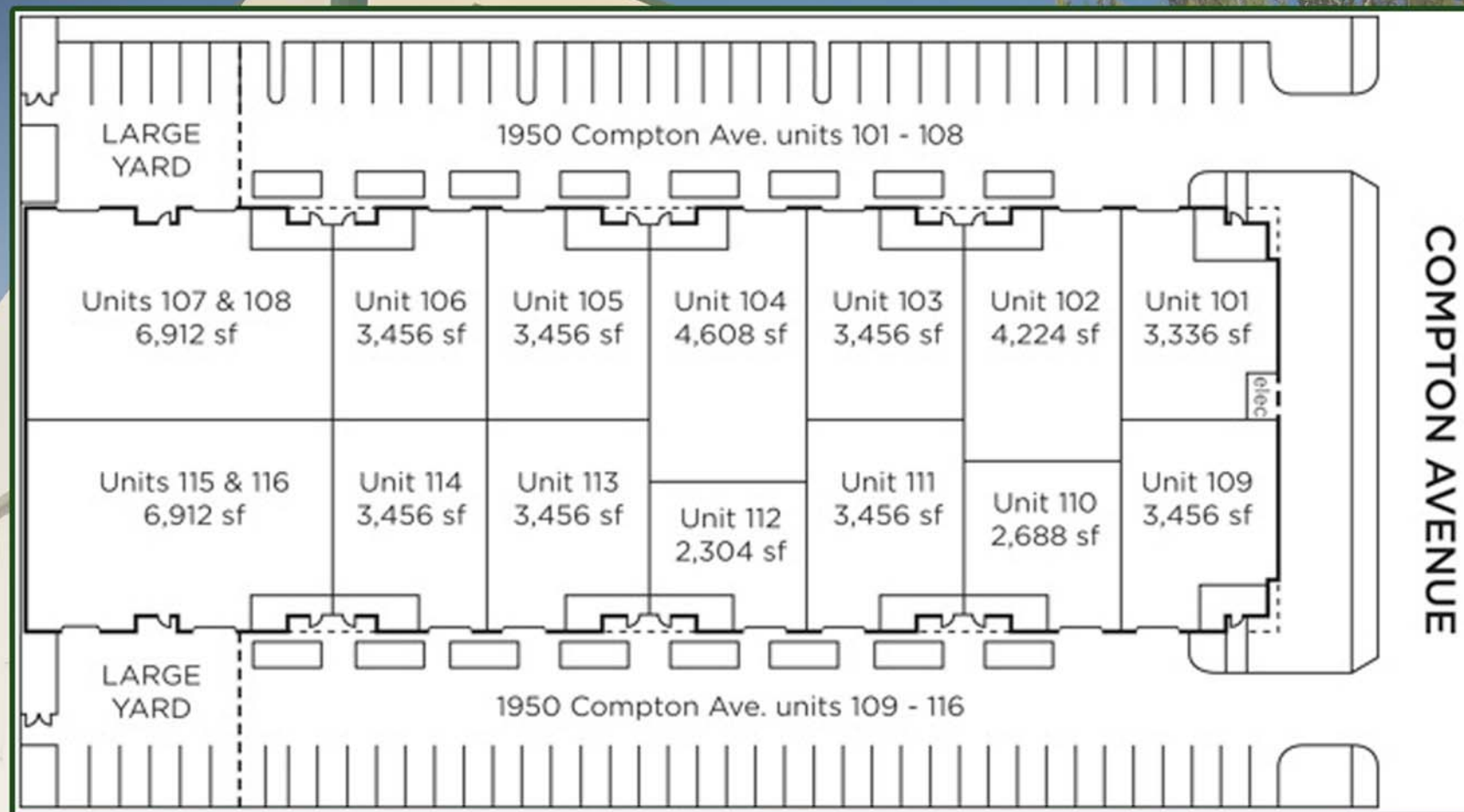

PROFESSIONALLY
MANAGED BY: 951-837-2101



DOUG C. EARNHART, SIOR
LICENSE #00884396
DEARNHART@LEE-ASSOC.COM

PAUL R. EARNHART, SIOR
LICENSE #00822072
PEARNHART@LEE-ASSOC.COM



3535 INLAND EMPIRE BLVD ONTARIO, CA 91764 P.909.989.7771 F.909.373.2968